

# DH-PFA130-E

## Water-proof Junction Box



### Features

- Neat & Integrated design
- Material: Aluminum
- IP66 junction box

### Technical Specifications

<b>Model</b>	<b>DH-PFA130-E</b>
<b>General</b>	
Material	Aluminum
Dimension	Φ124mmx41mm(φ4.88"x1.61")
Pipe thread	G3/4"
Weight	0.35kg(0.77lb)
Load bearing	3.0kg(6.61lb)
Color	Black
Protection	IP66
Operating temperature	-40°C ~60°C(-40°F ~+140°F)
Humidity	<90% RH
Applicable model	Please see "Accessory Selection"

### Dimensions (mm/inch)

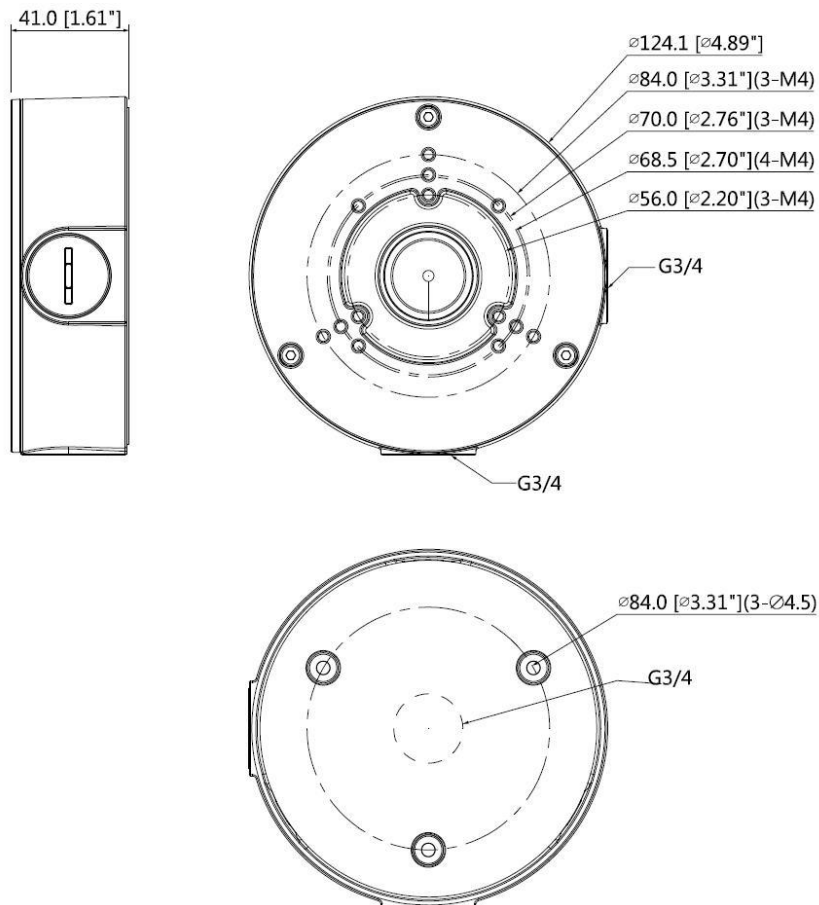

## Application

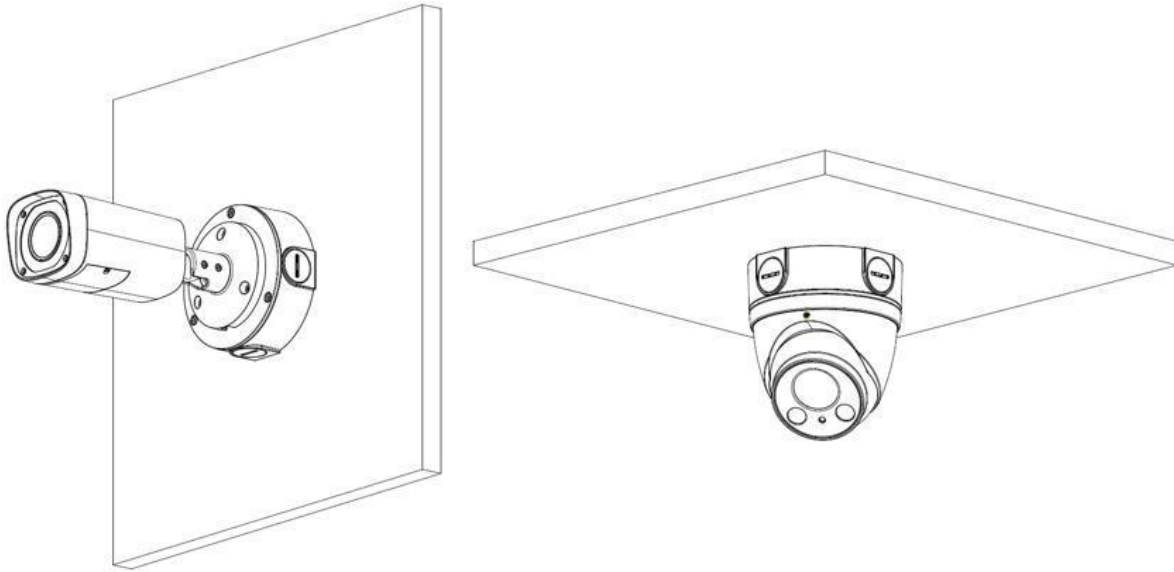

## Package Information

- Water-proof junction box DH-PFA130-E \*1
- M4x10 screw \*4
- ST4.2x25 screw \*3
- Plastic Anchor: 3
- Mounting sticker \*1
- S3.0 wrench \*1