

# HDCVI Camera User's Manual

Version 1.0.1

# Table of Contents

|       |                               |    |
|-------|-------------------------------|----|
| 1     | General Introduction .....    | 1  |
| 1.1   | Overview .....                | 1  |
| 1.2   | Features.....                 | 1  |
| 2     | Framework and Dimensions..... | 2  |
| 3     | Installation .....            | 6  |
| 4     | Menu.....                     | 9  |
| 4.1   | HCVR Settings.....            | 9  |
| 4.1.1 | Control Coaxial Device .....  | 9  |
| 4.1.2 | Set Audio Coax.....           | 9  |
| 4.2   | Menu Operation .....          | 10 |
|       | Appendix Maintenance .....    | 12 |

# Welcome

Thank you for purchasing our HDCVI camera!

This user's manual is designed to be a reference tool for your system.

Please read the following safeguard and warnings carefully before you use this series product!

Please keep this user's manual well for future reference!

## Important Safeguards and Warnings

### Electrical safety

All installation and operation here should conform to your local electrical safety codes.

The power shall conform to the requirement in the SELV (Safety Extra Low Voltage) and the Limited power source is rated DC 12V or AC24V in the IEC60950-1. (Power supply requirement is subject to the device label).

Please install easy-to-use device for power off before installing wiring, which is for emergent power off when necessary.

Please check if the power supply meets the requirements of working voltage of the camera before operating the device (The material and length of the power supply cable will influence terminal voltage value).

Please prevent the line cord from being trampled or pressed, especially the plug, power socket and the junction from the device.

### Environment

Please don't aim the device at strong light (such as lighting, sunlight and so on) to focus.

Please transport, use and store the device within the range of allowed humidity and temperature.

Please do not allow water and other liquid falling into the camera in case that the internal components are damaged.

Please keep the sound ventilation in case of heat accumulation.

Heavy stress, violent vibration or water splash are not allowed during transportation, storage and installation.

Please pack the device with standard factory packaging or material with same quality when transporting the device.

It is recommended to use the device together with lightning protection device to enhance lightning protection effect.

It is recommended to GND the device to enhance device reliability.

It is advised to use qualified video transmission cable to improve video quality. It is recommended to use 75-3 coaxial cable or higher standard.

### Warning

Please use the standard accessories provided by manufacturer and make sure the device is installed and fixed by professional engineers.

Please prevent the device surface from the radiation of laser beam when using laser beam device.

Please do not provide two or more power supply modes for the device, otherwise it may cause damage to the device.

## Statement

Please refer to the actual product for more details; the manual is just for reference.

The manual will be regularly upgraded according to the product update; the upgraded content will be added in the manual without prior announcement.

Please contact the customer service for the latest procedure and supplementary documentation.

The company is not liable for any loss caused by the operation which is not followed by the manual.

Please refer to the company's final explanation if there is any doubt or dispute.

# 1 General Introduction

## 1.1 Overview

This series megapixel HD camera conforms to the HDCVI standard. It supports video signal high-speed long distance transmission without any delay. It can be controlled by the HCVR conforming to the HDCVI

## 1.2 Features

- High-performance CMOS image sensor, megapixel definition.
- Support HD video and control signal coaxial transmission.
- Support 75-3 coaxial cable transmission without any loss. 720P series transmission distance over 800m, 1080P series transmission distance over 500m.
- High speed, long distance real-time transmission.
- Support HDCVI HD and analog SD output.
- Support 3D noise reduction, excellent low illuminance performance.
- Support ICR switch to realize monitoring both in daytime and at night.
- Support WDR (Some models only supports DWDR).
- Support OSD menu to adjust parameters.
- Support smart IR function.
- Support DC 12V/AC 24V power supply (AC 24V is only supported by some models).
- IP67 compliance.
- It can be applied to the places with HD image request, such as bank, supermarket, telecom, government, school, airport, factory, hotel and etc.

## 2 Framework and Dimensions

See Figure 2-1 for the dimension of **model A**. The unit is mm.

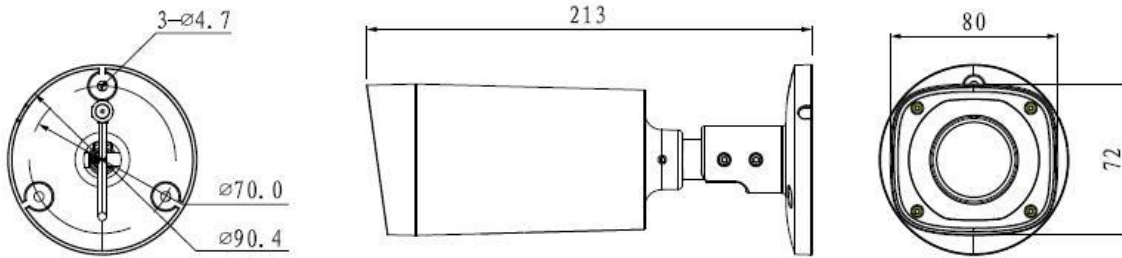

Figure 2-1

See Figure 2-2 for the dimension of **model B**. The unit is mm.

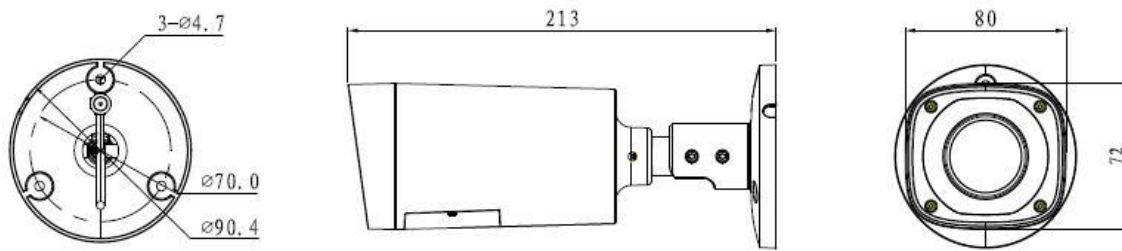

Figure 2-2

See Figure 2-3 for the dimension of **model C**. The unit is mm.

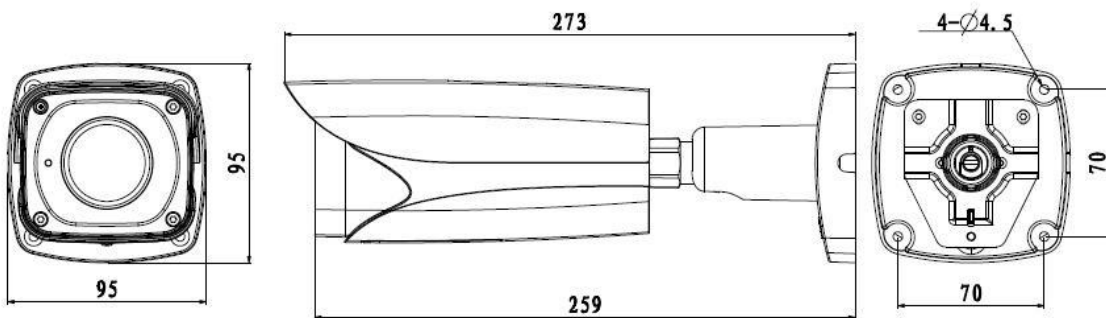

Figure 2-3

See Figure 2-4 for the structure components of model A and B.

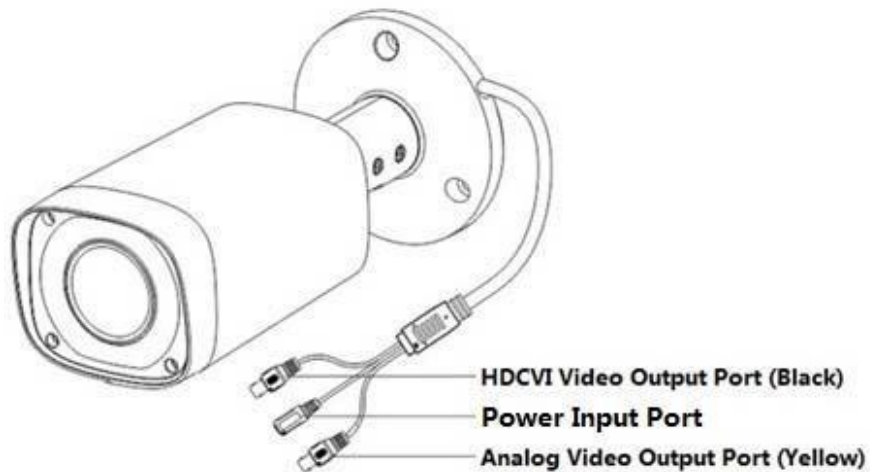

Figure 2-4

See Figure 2-5 for the structure components of model B

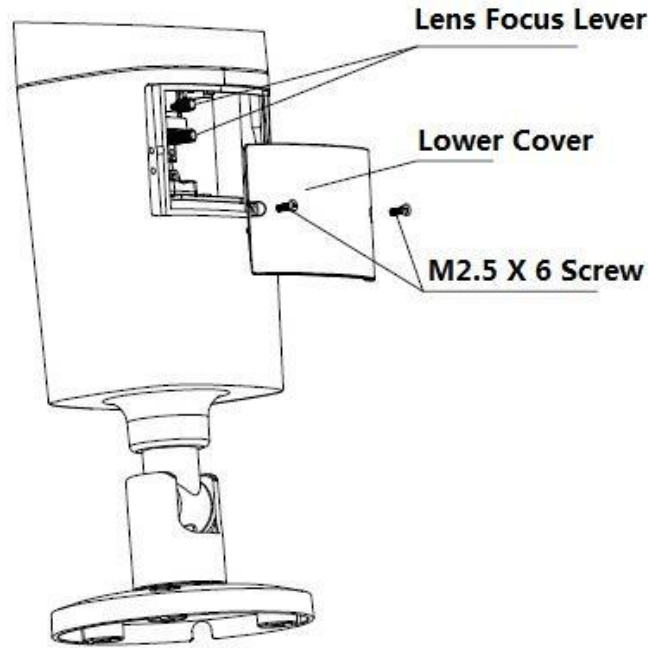

Figure 2-5

See Figure 2-6 and Figure 2-7 for the structure components of model C.

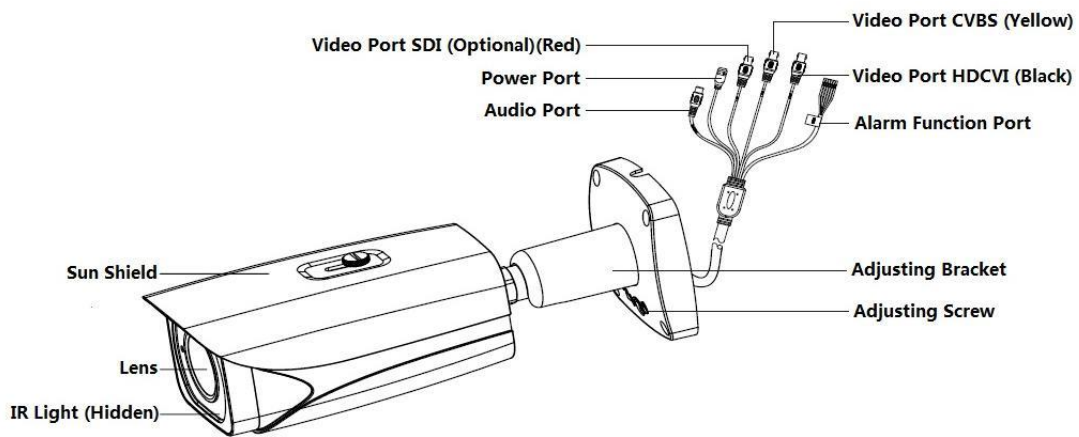

Figure 2-6

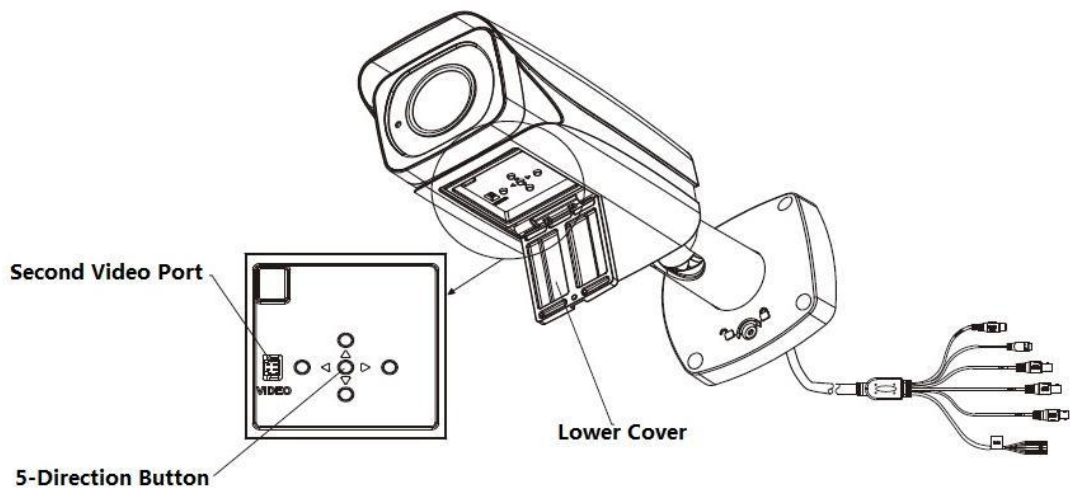

Figure 2-7

Refer to Sheet 2-1 for more details about cable port.

| Cable color | Port name                | Function  |
|-------------|--------------------------|---|
| Green       | ALARM_NO                 | On-off alarm output port  |
| Orange      | ALARM_NC                 | On-off alarm output port  |
| Red         | ALARM_IN                 | Alarm signal input port   |
| Black       | ALARM_GND                | Alarm signal input GND port   |
| -           | Audio input port         | External audio source input.<br>Note:<br><ul style="list-style-type: none"> <li>● It needs to set the camera "Audio Mode" as "External Audio" when using external audio source input.</li> <li>● External audio source has to be analog audio.</li> </ul> |
| -           | Power input port         | Input DC12V/AC 24V.   |
| -           | Analog video output port | Output analog SD video signal   |
| -           | Video port SDI           | Output digital HD video signal  |
| -           | HDCVI video output port  | Coaxial transmission of video, audio signal, it needs to connect to back-end HCVR to control.   |

Sheet 2-1

**Note:**

When using 5-direction button to operate OSD menu, the left and right buttons fail to realize vari-focal and zoom function, then it needs to exit OSD menu and operate it again.

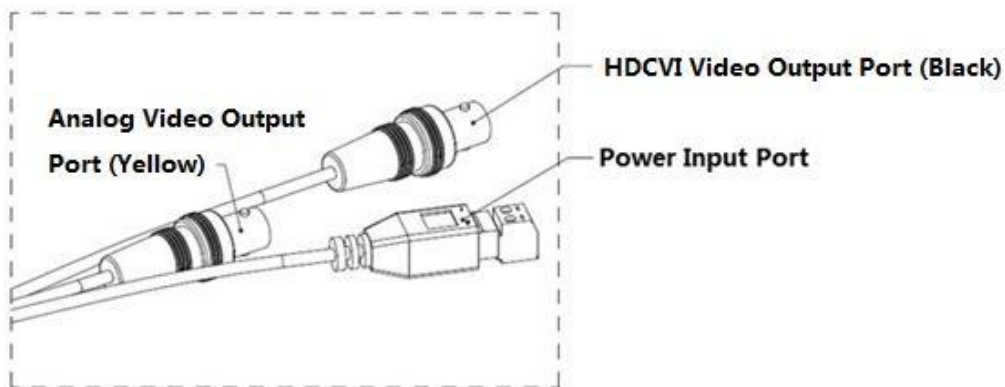

Figure 2-8

**Note:**

Camera models with dual power use the cable structure shown in Figure 2-8; the power input port supports DC12V/AC24V power supply.



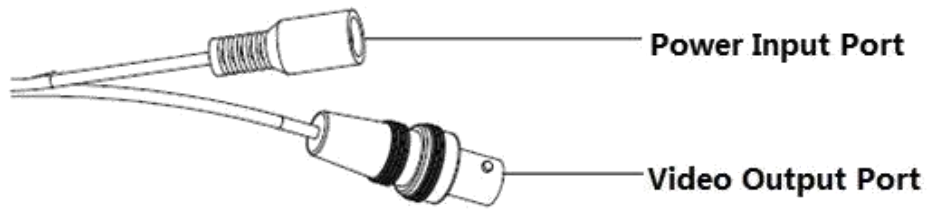

Figure 2-9

**Note:**

There is only one video port for some cameras, which is shown in Figure 2-9, it outputs HD video signal by default, it needs to enable self-adaptation function in the OSD menu to switch to standard definition video signal.

### 3 Installation

#### Important

- Please install the device in time after it is taken apart, which is to avoid the camera module being exposed to damp environment for too long.
- Before the installation, please make sure the installation surface should be thick enough to sustain at least 3X weight of the camera.

#### Step 1

Take out the installation position map from the accessories bag, stick it on the ceiling or wall according to the cable exit, dig holes on the installation surface according to the installation position map, and see Figure 3-1. Pull out the camera cable through the cable exit on the bracket pedestal, and install camera bracket.

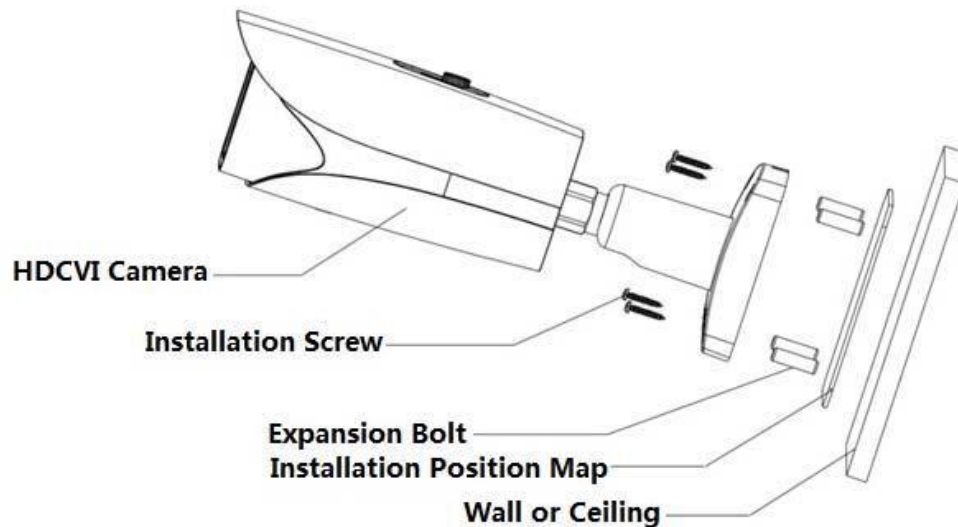

Figure 3-1

- If it is cement wall, it needs to install expansion bolt first (the installation holes of expansion bolt need to be in accordance with bracket), then use self-tapping screws to install bracket.
- If it is wooden wall, you can just skip the first step, use self-tapping screws to install bracket directly.

#### Step 2 Adjust the camera monitoring direction

- If it is the model c or c (1), then use the L-shaped wrench in the accessories bag to loosen the adjusting screws, adjust the camera to the specific direction which needs to be monitored, then use L-shaped wrench to tighten adjusting screws and fix the camera, see Figure 3-2.

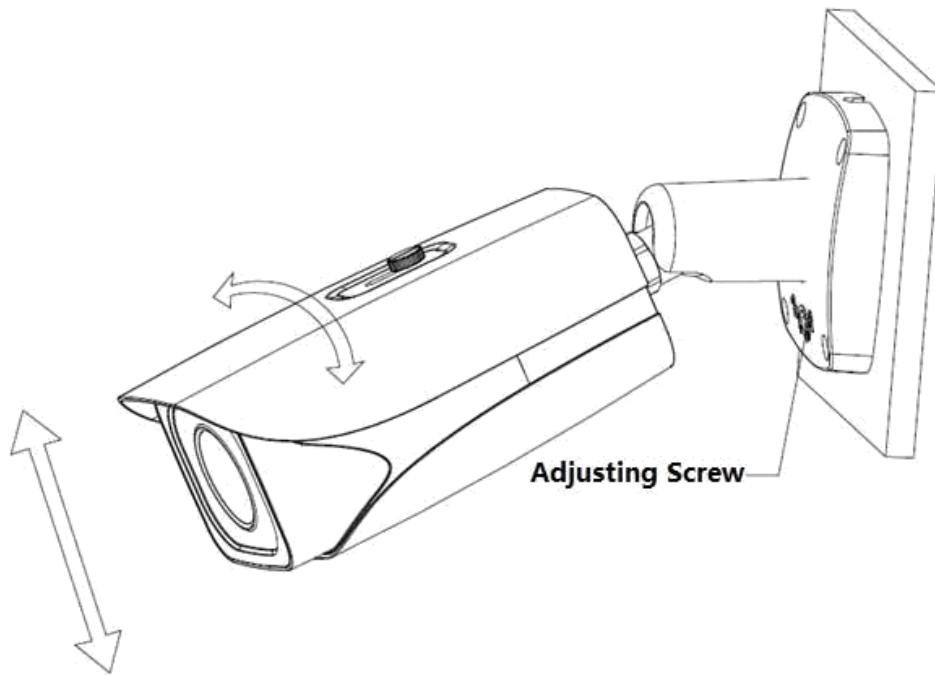

Figure 3-2

- If it is model a or model b, then loosen the M3 X 20 and M3 X 5 screws on the bracket according to the direction shown in Figure 3-3, adjust the camera to specific monitoring direction via rotating bracket and camera body, then fix the screws.

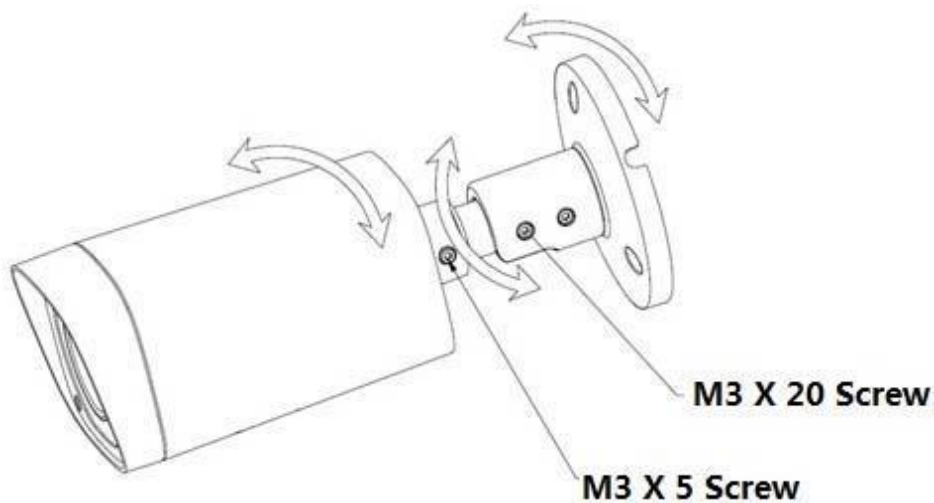

Figure 3-3

### Step 3

Connect the video output port of device cable to the back-end HCVR device, and connect power port to power supply.

### Step 4 Adjust camera zoom and focus

- If it is the model a, then it needs to adjust lens zoom and focus on the back-end HCVR device to make the image clear.

- If it is the model b, after displaying image on the back-end HCVR device, open the camera lower cover and adjust lens focal length via focus/zoom lever to make image clear, and then tighten the lever. Retighten the camera lower cover and complete camera installation.

**Note:**

The installation figures above are for reference only.

## 4 Menu

### 4.1 HCVR Settings

#### 4.1.1 Control Coaxial Device

This HDCVI camera series can adjust OSD menu via coaxial control. After connected the camera to the HDCVI series HCVR, from Main Menu->Setting->System->PTZ, you need to select the channel number for access and set control mode as HDCVI and the protocol as HD-CVI. Click “Save” button to save current setup. See Figure 4-1.



Figure 4-1

#### 4.1.2 Set Audio Coax

From “Main Menu > Setting > Camera > Encode > Encode”, you need to set “Audio Format” as “G711a” and the “Audio Source” as “HDCVI”. See Figure 4-2 for more details.



Figure 4-2

## 4.2 Menu Operation

Click the right mouse button and select “PTZ Control”, then you will see the “PTZ Setup” menu, which is as shown in Figure 4-3 and Figure 4-4.



Figure 4-3



Figure 4-4

See Sheet 4-1 for the details of button functions.

| Button | Function                                |   |
|--------|---|---|
|        | Open menu                               |   |
|        | Select menu item                        |   |
|        | Select menu value                       |   |
|        | Adjust lens zoom and auto trigger focus | Note:<br>Some of the buttons can only be applied for the motorized vari-focal camera. |
|        | Adjust lens focus                       |   |
|        | Auto focus under current zoom rate      |   |
|        | Lens reset                              |   |

Sheet 4-1

If there is “↵”, click the “Confirm” button in “Menu Operation” interface to go to the 2nd menu. Click “Return” button to go back to the previous menu interface.

## Appendix Maintenance

Attention:

Please maintain the device according to the following instructions in order to ensure the image effect and long-term stable operation of the device.

### **Maintenance for lens and mirror surface**

The lens and mirror surface are covered with antireflection coating, so it may produce hazardous substance and lead to performance reduction or scratch, dimness etc when it is stained with dust, grease, fingerprint and so on, please refer to the following methods to deal with once dirt is found:

Stained with dirt

Use oil-free soft brush or hair dries to remove it gently.

Stained with grease or fingerprint

Use soft cloth to wipe the water drop or oil gently to make it dry, then use oil-free cotton cloth or paper soaked with alcohol or detergent to wipe from the lens center to outward. It is ok to change the cloth and wipe several times if it is not clean enough.

### **Camera Body Maintenance**

Use a soft dry cloth to clean the camera body when it is dirty, in case the dirt is hard to remove, use a clean dry cloth soaked with mild detergent and wipe gently, make it dry later. Don't use volatile solvent like alcohol, benzene, thinner and etc or strong detergent with abrasiveness, otherwise it will damage the surface coating or reduce the working performance of the device.

### **Maintenance for Dome Cover**

Dome cover is an optical device, please don't touch or wipe cover surface directly during installation and use, please refer to the following methods to deal with once dirt is found:

Stained with dirt

Use oil-free soft brush or hair dries to remove it gently.

Stained with grease or fingerprint

Use soft cloth to wipe the water drop or oil gently to make it dry, then use oil-free cotton cloth or paper soaked with alcohol or detergent to wipe from the lens center to outward. It is ok to change the cloth and wipe several times if it is not clean enough.



## **Note**

**This manual is for reference only. Slight difference may be found in the user interface.**

**All the designs and software here are subject to change without prior written notice.**

**All trademarks and registered trademarks mentioned are the properties of their respective owners.**

**If there is any uncertainty or controversy, please refer to the final explanation of us.**

**Please visit our website or contact your local service engineer for more information.**