

## Pinhole Pickup



### Features

- Omni-directional condenser microphone, high fidelity;
- 30KV Air contact ESD, built-in Lightning Protection, power supply polarity reversal protection and electrostatic protection;
- Pinhole design, hidden installation; match with cameras or storage devices which have audio function!

### Specifications

Properties	
Scope	5-40m <sup>2</sup>
Sensitivity	-40dB(-45~-20dB adjustable)
Frequency response	20Hz~20kHz
Directional characteristic	Omni-directional
SNR	70dB(1m 40dB sound source SPL)
Dynamic range	104dB(1KHz at Max dB SPL)
Max. sustainable sound pressure	120dB SPL(1KHz, THD 1%)
Output impedance	600Ω(non-equilibrium)
Output signal amplitude	2.5Vpp/-25dB
Working voltage	DC 12V(9~15V)
Working current	60mA(50~100mA)
Working temperature	-30°C~+70°C
Color	White
Outer shell	PC
Dimension	63mmx30mmx22mm
Weight	34g
Carried standard	CE/FCC

---

## Dimensions (mm)

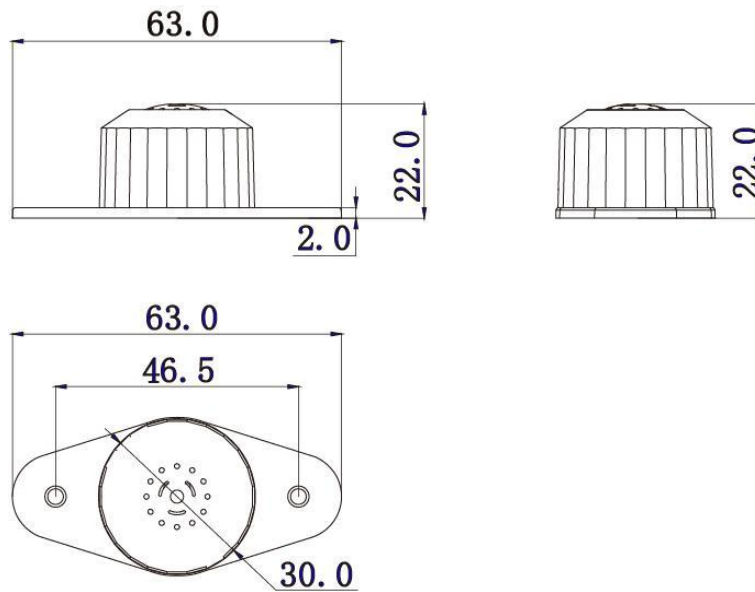

---

### Dahua Technology Co., Ltd.

1199 BinAn Road, Binjiang District, Hangzhou, China

Tel: +86-571-87688883

Fax: +86-571-87688815

Email: [overseas@dahuatech.com](mailto:overseas@dahuatech.com)

[www.dahuasecurity.com](http://www.dahuasecurity.com)

\*Design and specifications are subject to change without notice.

© 2016 Dahua Technology Co., Ltd.