

DH-PFM320D-015

DC12V1.5A Power Adapter



Features

- Easy installation
- Support working with indicator light
- Support $-30\text{ }^{\circ}\text{C} \sim +70\text{ }^{\circ}\text{C}$ wide-range temperature operation, and the full load efficiency of the power supply can be up to 100% at these temperatures
- Accurate overcurrent, overvoltage protection

Technical Specifications

Model	DH-PFM320D-015
Electrical Specification	
Rated input	AC100~240V, 50/60Hz, 0.6A
Output voltage	DC12V (+7%, -3%)
Output current	Max. 1.5A (+70°C)
Protection/Environmental	
Protection	Surge protection, over temperature protection, over current, voltage load protection
	ESD: EN61000-4-2 +/-6kV Contact; +/-8kV Air
	Surge: EN61000-4-5 Combination Wave: Common Mode ± 4KV(12 ohms) Differential Mode ± 2kV(2 ohms)
Working temperature	-30°C ~ +70°C (-22°F ~ +158°F)
Working humidity	5%~95% RH
Physical Properties	
Weight	95g(0.21lb)
Dimension(LxWxH)	77.3mmx51.9mmx30.0mm(3.04"x2.04"x1.18")
Installation	Plane installation, can be installed in junction boxes and wall mount brackets
Color	White
Input plug	2-pin plug(L/N)
Output plug	2-pin plug(+12V-)
Safety Standards	
Certification	CE, FCC

Dimensions (mm/inch)

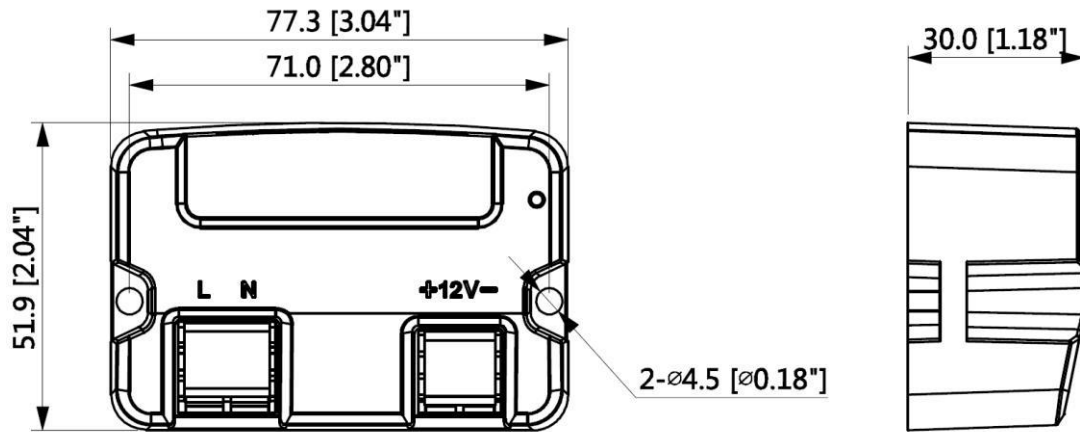

Application

- Support to be installed in some brackets, such as junction box PFA12X and wall mount bracket PFB302S/PFB210W.

