

8MP HDCVI IR-Fisheye Camera



HDCVI

- 1/2" 8 Megapixel progressive scan CMOS
- Panoramic fisheye lens
- Max. 15fps@4K
- 120db true WDR,2D&3D NR
- On-device lens distortion correction
- Max.15m IR distance
- IP67&IK10 ingress protection
- Up to 500m transmission with RG59 coaxial cable



System Overview

The 4K HDCVI fisheye camera adopts a panoramic fisheye lens and 1/2" 8MP high performance image sensor, as well as a 15m IR range, enabling a full overview and superior image details with 4K resolution. That makes it easy to collect evidence at any time of day for effective playback and analysis. With the use of advanced algorithms, more than 10+ dewarping modes are available on the XVR (select models) and mobile client. Its panoramic view and 4K resolution makes the camera an ideal choice for large-size businesses and places such as airports, stadiums, parking lots, and shopping malls.

Functions

Fisheye Panoramic View

HAC-EBW3802 offers a panoramic view based on three installation modes(ceiling/ground/wall)with up to 95% sensor pixel utilization.As a result you can recognize a person's face over 10 meters away.The camera is able to provide a crystal clear image and broad coverage of wide and open areas, such as airports, shopping malls, retail stores, offices and more.So you will get a overall sight just with one fisheye camera over coax.

Fisheye-Dewarping

Fisheye dewarping is a function to solve the serious distortion problem of the circular panoramic view and you will use up to 10-modes dewarping mode for different installations with HDCVR,Web and SmartPSS.Every dewarping area is adjustable and optional as you want.

On-Device Lens Distortion Correction

On-device lens distortion correction is another great innovation of HDCVI technology for correcting the fisheye panoramic image to a 16:9 full screen with two optional modes by the camera itself.One is Vertical&Horizontal (V&H)mode which can provide an image without any distortion and angle of view is about H:170°,V:88°.Another is Vertical(V) mode that can enable the camera to output an image with H:176°,V:73° view angle.

4 Signals over 1 Coaxial Cable

HDCVI technology supports 4 signals to be transmitted over 1 coaxial cable simultaneously, i.e. video, audio*, data and power. Dual-way data transmission allows the HDCVI camera to interact with the HCVR, such as sending control signal or triggering alarm. Moreover, HDCVI technology supports PoC for construction flexibility.

* Audio input is available for some models of HDCVI cameras.

Long Distance Transmission

HDCVI technology guarantees real-time transmission at long distance without any loss. It supports up to 700m transmission for 4K and 4MP HD video via coaxial cable, and up to 300m via UTP cable.*

*Actual results verified by real-scene testing in Dahua's test laboratory.

Simplicity

HDCVI technology inherits the born feature of simplicity from traditional analog surveillance system, making itself a best choice for investment protection. HDCVI system can seamlessly upgrade the traditional analog system without replacing existing coaxial cabling. The plug and play approach provides full HD video surveillance without the hassle of configuring a network.

Multi-outputs

The camera supports HDCVI and CVBS signal outputs simultaneously with two BNC connectors. Multi-outputs facilitates construction in situations such as debugging with a tester. It also offers the possibility for cooperating with multiple devices including analog matrix or monitor.

Wide Dynamic Range

Embedded with industry leading wide dynamic range (WDR) technology, vivid pictures are achieved even in the most intense contrast lighting conditions. True WDR (120dB) optimizes both the bright and dark areas of a scene at the same time to provide usable video.

Advanced 3DNR

3DNR is noise reduction technology that detects and eliminates random noises by comparing two sequential frames. Dahua's advanced 3DNR technology allows remarkable noise reduction with little impact to sharpness, especially under limited lighting condition. Besides, the advanced 3DNR effectively decreases the band width and saves the storage space.

Protection

The camera's outstanding reliability is unsurpassed due to its rugged design. The camera is protected against vandalism with IK10-rated, making it suitable for most environment such as retail stores,manufacturing and commercial facilities.

Supporting ±25% input voltage tolerance, this camera suits even the most unstable power supply conditions. Its 4KV lightning rating provides protection against the camera and its structure from the effects of outdoor lightning.

Technical Specification

Camera

Image Sensor	1/1.8" 8MP CMOS
Effective Pixels	3840(H)×2160(V)
Scanning System	Progressive
Electronic Shutter Speed	PAL:1/4s~1/100,000s NTSC:1/3s~1/100,000s
Minimum Illumination	0.005Lux/F2.0 (Color), 30IRE,0lux IR on
S/N Ratio	More than 65dB
IR Distance	15m
IR On/Off Control	Auto (ICR)/Color/B/W
IR LEDs	3
Audio	Built-in mic

Lens

Lens Type	Fixed lens / Fixed iris
Mount Type	Board-in
Focal Length	2.5mm
Max Aperture	F2.0
Angle of View	H: 180°,V:100°
Focus Control	N/A
Close Focus Distance	0.6m(23.6")

DORI Distance

Note: The DORI distance is a "general proximity" of distance which makes it easy to pinpoint the right camera for your needs. The DORI distance is calculated based on sensor specification and lab test result according to EN 62676-4 which defines the criteria for Detect, Observe, Recognize and Identify respectively.

	DORI Definition	Distance
Detect	25px/m (8px/ft)	53m(173.8ft)
Observe	63px/m (19px/ft)	21.2m(69.6ft)
Recognize	125px/m (38px/ft)	10.6m(34.7ft)
Identify	250ppm (76px/ft)	5.3m(17.4ft)

Pan / Tilt / Rotation

Pan/Tilt/Rotation	Pan: NA Tilt: NA Rotation: NA
-------------------	-------------------------------------

Video

Resolution	8MP (3840×2160)/4M(2560×1440)
Frame Rate	PAL:3840×2160@12.5fps,2560x1440@25fps; NTSC:3840×2160@15fps,2560x1440@30fps;
Video Output	1-channel HDCVI 4K video output & 1-channel CVBS video output

Day/Night	Auto (Electronic) / Manual
OSD Menu	Multi-language
BLC Mode	BLC / HLC / WDR
WDR	120dB
Gain Control	AGC
Noise Reduction	2D/3D
White Balance	Auto / Manual
Smart IR	Auto / Manual

Certifications

Certifications	CE (EN55032, EN55024, EN50130-4) FCC (CFR 47 FCC Part 15 subpartB, ANSI C63.4-2014) UL (UL60950-1+CAN/CSA C22.2 No.60950-1)
----------------	---

Interface

Alarm I/O	2/1
-----------	-----

Electrical

Power Supply	DC12V ±25%
Power Consumption	7.4W (IR ON)

Environmental

Operating Conditions	-30°C ~ +60°C (-22°F ~ +140°F) / Less than 95% RH * Start up should be done at above -30°C (-22°F)
Storage Conditions	-30°C ~ +60°C (-22°F ~ +140°F) / Less than 95% RH
Ingress Protection & Vandal Resistance	IP67&IK10

Construction

Casing	Aluminium
Dimensions	Φ149.8mm x 47.7mm(Φ5.9"x 1.88")
Net Weight	0.56kg (1.23lb)
Gross Weight	0.92kg (2.02lb)

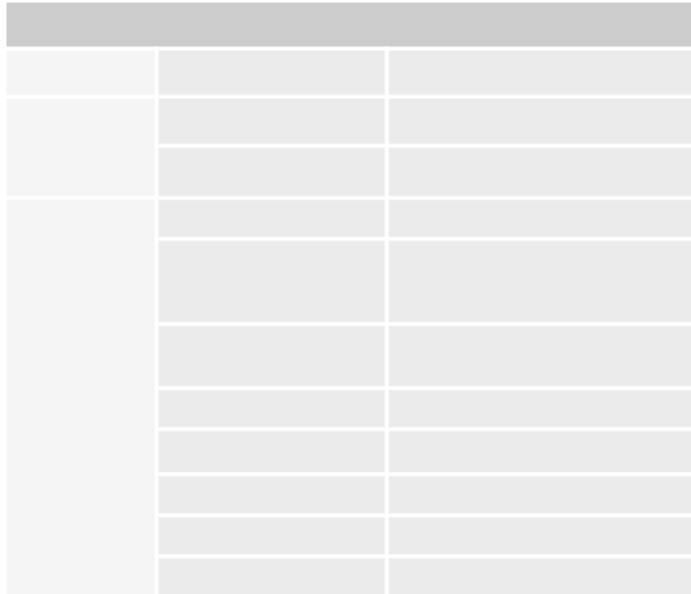

Dimensions (mm/inch)

Optional:



PFA100
Mount adapter



PFB302S
Wall mount



PFA152-E
Pole mount



PFB300C
Ceiling Mount



PFM800-E
Passive HDCVI Balun



PFM320
12V 2A Power Adapter



PFM320D-015
Power Adapter

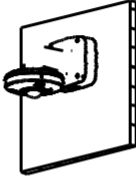
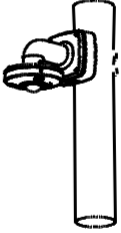
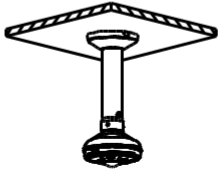

PFM321
12V 1A Power Adapter

Wall Mount	
PFA100+PFB302S	PFA100+PFB302S+PFA152-E
	
Ceiling Mount	
PFA100+PFB300C	
	

Dimensions (mm/inch)

