

5MP WDR IR Eyeball Network Camera



- 1/2.7" 5Megapixel progressive CMOS
- H.265& H.264 dual-stream encoding
- 15fps@5M(2592×1944) & 25/30fps@3M(2304×1296)
- WDR(120dB), Day/Night(ICR), 3DNR, HLC, AGC, BLC
- Multiple network monitoring: Web viewer, CMS(DSS/PSS) & DMSS
- 2.8 mm fixed lens (3.6mm optional)
- Max IR LEDs Length 30m
- IP67, PoE



System Overview

The IR Megapixel Fixed camera delivers 5MP resolution with a 2.8mm/3.6mm fixed lens. The camera's elegant blend of aesthetics combined with a range of easy mounting solutions provides an excellent choice for a variety of small to mid-size applications at an affordable price.

Functions

Smart Codec (H.265+ & H.264+)

Smart Codec is the optimized implementation of standard video compression (H.265 & H.264) that uses a scene-adaptive encoding strategy, dynamic GOP, dynamic ROI, flexible multi-frame reference structure and intelligent noise reduction to deliver high-quality video without straining the network. Smart Codec technology reduces bit rate and storage requirements by up to 70% when compared to the standard video compression.

Intelligent Video Analysis (IVS)

Dahua camera is equipped with a built-in intelligent analytic algorithm based on video, which can realize intelligent functions like Tripwire and Intrusion, to quickly and accurately respond to monitoring events in specific area. It can enhance monitoring efficiency. In addition, the camera supports intelligent tamper detection, which is to generate warning message via detecting dramatic scene change and to guarantee effective video surveillance.

Wide Dynamic Range (WDR)

The camera achieves vivid images, even in the most intense contrast lighting conditions, using industry-leading wide dynamic range (WDR) technology. For applications with both bright and low lighting conditions that change quickly, true WDR (120 dB) optimizes both the bright and dark areas of a scene at the same time to provide usable video.

Smart IR Technology

With IR illumination, detailed images can be captured in low light or total darkness. The camera's Smart IR technology adjusts the intensity of camera's infrared LEDs to compensate the distance of an object. Smart IR technology prevents IR LEDs from whitening out images as they come closer to the camera. The camera's integrated infrared illumination provides high performance in extreme low-light environments up to 30m (98ft).

Protection (IP67, wide voltage)

The camera allows for $\pm 25\%$ input voltage tolerance, suitable for the most unstable conditions for outdoor applications. Its 2KV lightning rating provides effective protection for both the camera and its structure against lightning. Subjected and certified to rigorous dust and immersion tests (IP67), the camera is the choice for installation in even the most unforgiving environments.

Environmental

Dahua cameras operate in extreme temperature environments, rated for use in temperatures from -30°C to $+60^{\circ}\text{C}$ (-22°F to $+140^{\circ}\text{F}$) with 95% humidity.

Image Flip

Capturing unnecessary data such as surrounding hallway walls can increase storage requirements without any added value. The image flip feature allows the camera's image to be rotated in 90° increments for better video optimization.

Interoperability

The camera conforms to the ONVIF (Open Network Video Interface Forum) specifications, ensuring interoperability between network video products regardless of manufacturer.

Technical Specification

Camera

| | |
|--------------------------|---|
| Image Sensor | 1/2.7" 5Megapixel progressive CMOS |
| Effective Pixels | 2592(H) x1944(V) |
| RAM/ROM | 512MB/32MB |
| Scanning System | Progressive |
| Electronic Shutter Speed | Auto/Manual, 1/3~1/100000s |
| Minimum Illumination | 0.03Lux/F2.0(Color,1/3s,30IRE) 0.3Lux/2.0(Color,1/30s,30IRE) 0Lux/F2.0(IR on) |
| S/N Ratio | More than50dB |
| IR Distance | Distance up to 30m(98ft) |
| IR On/Off Control | Auto/ Manual |
| IR LEDs | 12 |

Lens

| Lens Type | Fixed | | | | | | | | | | | | | | | |
|----------------------|---|-----------|-----------|----------|-----------|----------|--------|-----------|----------|----------|---------|--------|-----------|-----------|----------|---------|
| Mount Type | Board-in | | | | | | | | | | | | | | | |
| Focal Length | 2.8 mm (3.6 mm optional) | | | | | | | | | | | | | | | |
| Max. Aperture | F2.0/F2.0 | | | | | | | | | | | | | | | |
| Angle of View | H:96°/78°, V:70°/58° | | | | | | | | | | | | | | | |
| Focus Control | Fixed | | | | | | | | | | | | | | | |
| Close Focus Distance | N/A | | | | | | | | | | | | | | | |
| | <table border="1"> <thead> <tr> <th>Lens</th> <th>Detect</th> <th>Observe</th> <th>Recognize</th> <th>Identify</th> </tr> </thead> <tbody> <tr> <td>2.8 mm</td> <td>63(207ft)</td> <td>25(82ft)</td> <td>13(43ft)</td> <td>6(20ft)</td> </tr> <tr> <td>3.6 mm</td> <td>80(262ft)</td> <td>32(105ft)</td> <td>16(52ft)</td> <td>8(26ft)</td> </tr> </tbody> </table> | Lens | Detect | Observe | Recognize | Identify | 2.8 mm | 63(207ft) | 25(82ft) | 13(43ft) | 6(20ft) | 3.6 mm | 80(262ft) | 32(105ft) | 16(52ft) | 8(26ft) |
| Lens | Detect | Observe | Recognize | Identify | | | | | | | | | | | | |
| 2.8 mm | 63(207ft) | 25(82ft) | 13(43ft) | 6(20ft) | | | | | | | | | | | | |
| 3.6 mm | 80(262ft) | 32(105ft) | 16(52ft) | 8(26ft) | | | | | | | | | | | | |
| DORI Distance | | | | | | | | | | | | | | | | |

PTZ

| | |
|----------------|---|
| Pan/Tilt Range | Pan:0° ~360° ;Tilt:0° ~90° ;Rotation:0° ~360° |
|----------------|---|

Intelligence

| | |
|---------------|--|
| Event Trigger | Motion detection, Video tampering, Scene changing, Network disconnection, Ip address conflict, Illegal access, Storage anomaly |
| IVS | Tripwire, Intrusion |

Video

| | |
|----------------------|---|
| Compression | H.265/H.264H/MJPEG(Sub Stream) |
| Smart Codec | Support H.265+/H.264+ |
| Streaming Capability | 2 Streams |
| Resolution | 5M(2592x1944)/4M(2688x1520)/3M(2304x1296/2048x1536)/1080P(1920x1080)/720P(1280x720)/D1(704x576/704x480)/VGA(640x480)/CIF(352x288/352x240) |
| Frame Rate | Main Stream: 5M(1 ~ 15fps)/3M (1 ~ 25/30fps) Sub Stream: D1(1 ~ 25/30fps) |
| Bit Rate Control | CBR/VBR |

| | |
|--------------------------------------|---|
| Bit Rate | H.265: 12K ~ 8448Kbps H.264: 32K ~ 10240Kbps |
| Day/Night | Auto(ICR) / Color / B/W |
| BLC Mode | BLC / HLC / WDR(120dB) |
| White Balance | Auto/Natural/Street Lamp/Outdoor/Manual |
| Gain Control | Auto/Manual |
| Noise Reduction | 3D DNR |
| Motion Detection | Off / On (4 Zone, Rectangle) |
| Region of Interest | Off / On (4 Zone) |
| Electronic Image Stabilization (EIS) | N/A |
| Smart IR | Support |
| Digital Zoom | 16x |
| Flip | 0°/90°/180°/270° |
| Mirror | Off / On |
| Privacy Masking | Off / On (4 Area, Rectangle) |

Audio

| | |
|-------------|-----|
| Compression | N/A |
|-------------|-----|

Network

| | |
|---------------------|--|
| Ethernet | RJ-45 (10/100Base-T) |
| Protocol | HTTP;HTTPS;TCP;ARP;RTSP;RTP;RTCP;UDP;SMTP; FTP;DHCP;DNS;DDNS;PPPoE;IPV4/V6;QoS;UPnP; NTP;Bonjour;IEEE 802.1X;Multicast;ICMP;IGMP;TLS |
| Interoperability | ONVIF Profile S&G, API |
| Streaming Method | Unicast / Multicast |
| Max. User Access | 10 Users / 20 Users |
| Edge Storage | NAS Local PC for instant recording |
| Web Viewer | IE, Chrome, Firefox, Safari |
| Management Software | Smart PSS, DSS, DMSS |
| Smart Phone | IOS, Android |

Certifications

| | |
|----------------|--|
| Certifications | CE (EN 60950:2000) UL:UL60950-1 FCC: FCC Part 15 Subpart B |
|----------------|--|

Interface

| | |
|-----------------|-----|
| Video Interface | N/A |
| Audio Interface | N/A |
| RS485 | N/A |
| Alarm | N/A |

Electrical

| | |
|-------------------|------------------------------------|
| Power Supply | DC12V, PoE (IEEE 802.3af)(Class 0) |
| Power Consumption | < 6W |

Environmental

| | |
|----------------------|---|
| Operating Conditions | -30° C ~ +60° C (-22° F ~ +140° F) / Less than 95% RH |
| Storage Conditions | -30° C ~ +60° C (-22° F ~ +140° F) / Less than 95% RH |
| Ingress Protection | IP67 |
| Vandal Resistance | N/A |

Construction

| | |
|--------------|----------------------------|
| Casing | Metal+Plastic |
| Dimensions | Φ108mm×84.9mm(4.25"×3.15") |
| Net Weight | 0.23Kg(0.51lb) |
| Gross Weight | 0.387Kg(0.85lb) |

Accessories

Optional:

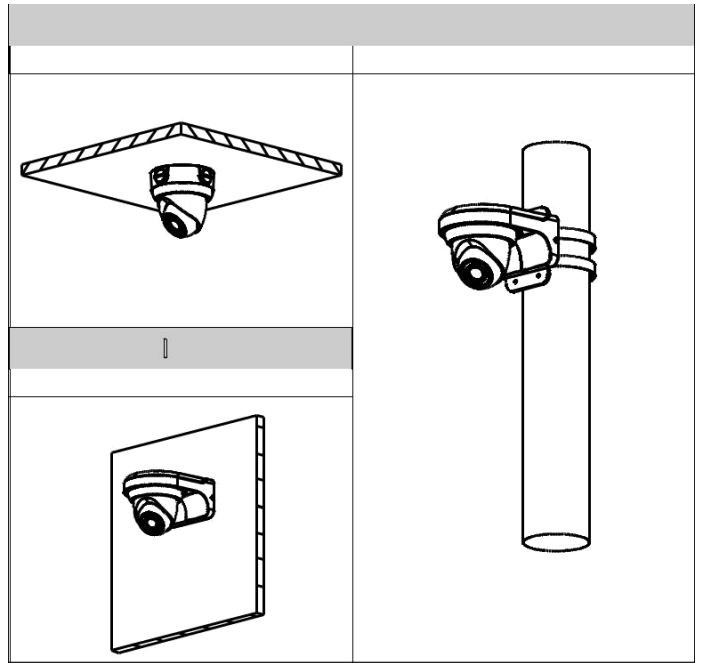

Dimensions (mm/inch)

