

DH-PFB121W

Wall Mount Bracket



Features

- Aesthetic design
- Wall mount bracket
- Material: aluminum

Technical Specifications

Model	DH-PFB121W
General	
Material	Aluminum
Dimension(WxHxD)	58mmx88mmx190.5mm (2.28"x3.46"x7.50")
Weight	0.24kg(0.53lb)
Load Bearing	1kg(2.2lb)
Color	White
Operating Temperature	-40°C~+60°C(-40°F~+140°F)
Humidity	<90% RH
Applicable Model	Please see "Accessory Selection"

Dimensions (mm/inch)

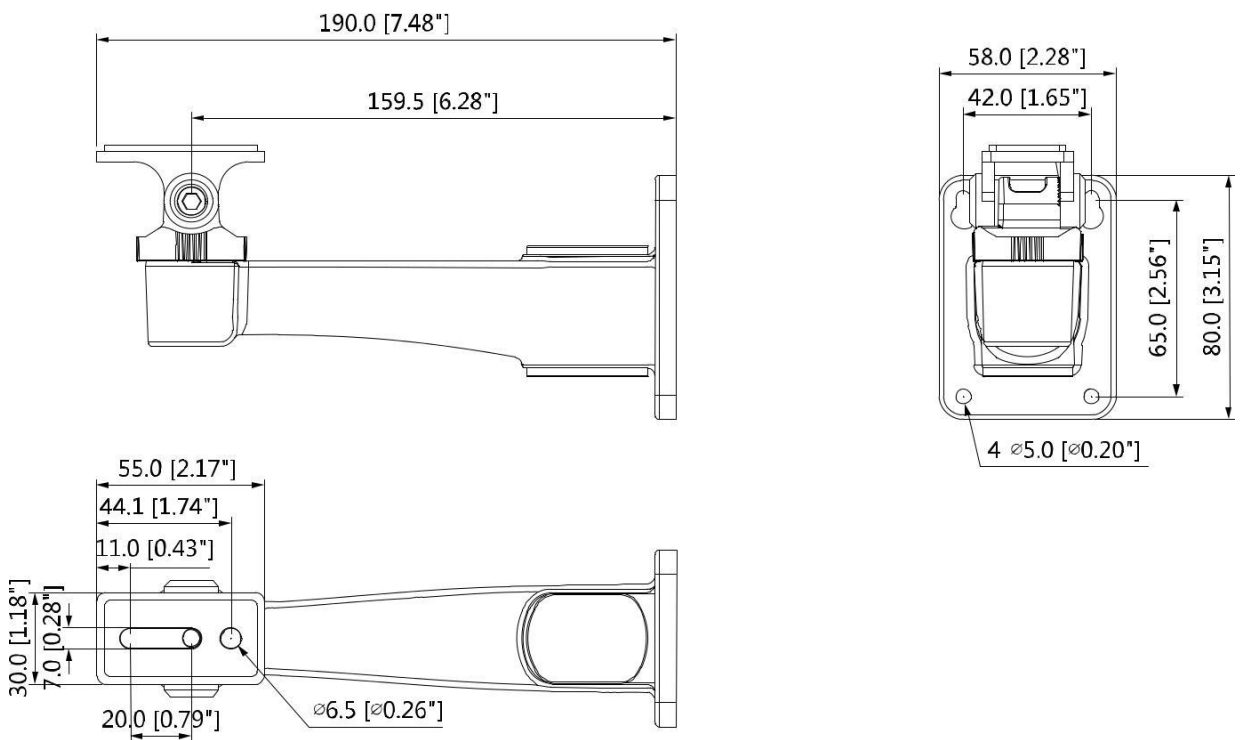

Application

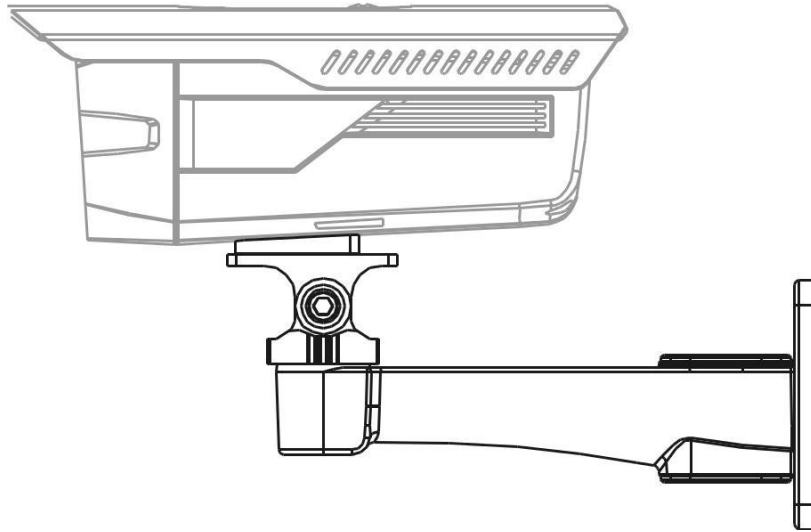

Package Information

- Wall mount bracket *1
- 1/4-20-10UNC *1
- ST4 screw *3
- Plastic anchor *4
- Wrench *1