

DH-PFA136

Water-proof Junction Box



Features

- Neat & Integrated design.
- Material: Aluminum
- Water-proof Junction box

Technical Specifications

Model	DH-PFA136
General	
Material	Aluminum
Dimension	Φ111.5mmx34mm(φ4.39"x1.34")
Inch Thread	M20(G1/2")
Load Bearing	1.0kg(2.2lb)
Weight	0.19kg(0.42lb)
Color	White
Operating Temperature	-40°C~+60°C(-40°F~+140°F)
Humidity	0~90% RH
Applicable Model	Please see "Accessory Selection"

Dimensions (mm/inch)

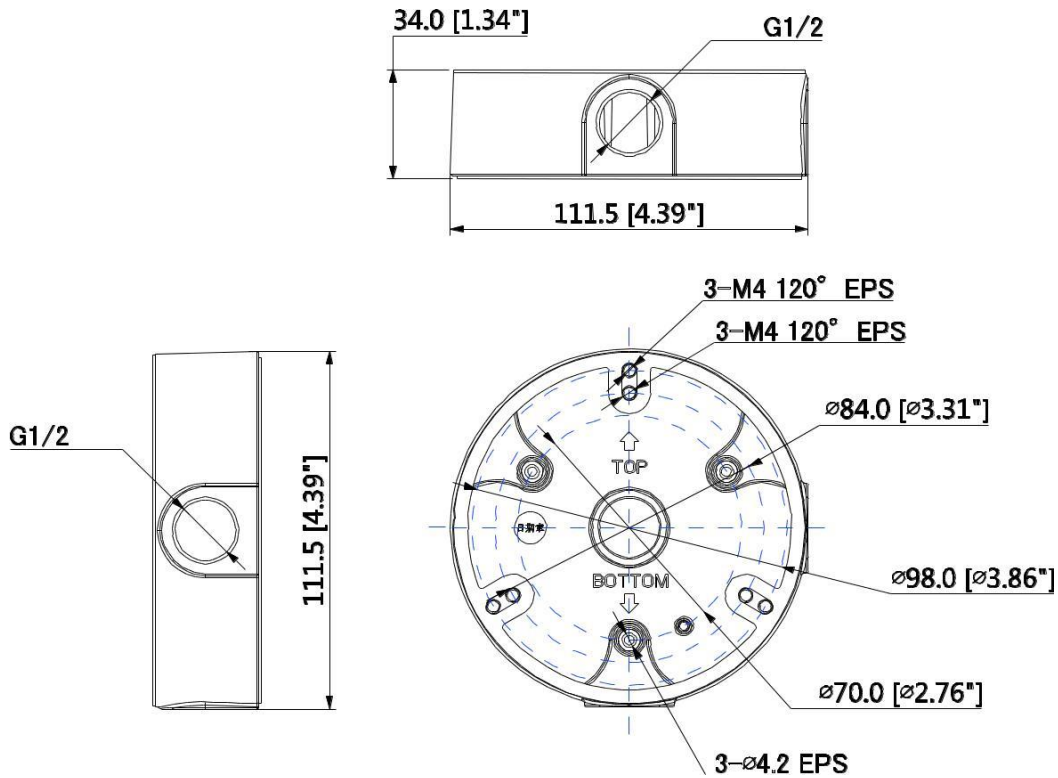

Application

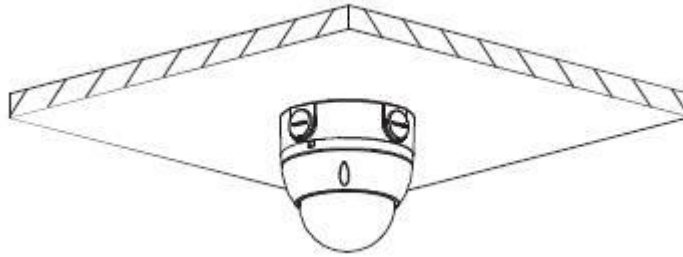

Package Information

- Water-proof junction box *1
- M4x10 screw *3
- ST4x25 screw *3
- Plastic anchor *3
- Water Joint *1
- Wrench *1

