

# DH-PFM300

## DC12V2A Power Adapter



### Features

- Easy installation and wall mount, structural water-proof;
- Support -30 °C ~+70 °C wide-range temperature operation, and the full load efficiency of the power supply can be up to 100% at these temperatures;
- With junction function for camera wiring or can place video balun with HDCVI/AHD/TVI/CVBS cameras;
- Made of PC environmental protection material, which meets "V0" fire protection;
- Accurate over current, voltage load protection.

## Technical Specifications

<b>Model</b>	<b>DH-PFM300</b>
<b>Electrical Specification</b>	
Rated input	AC180~264V, 50/60Hz, 0.6A
Efficiency	82%
no-load power consumption	<0.5W
Output voltage	DC12V (±5%)
Output current	2A (±2%)
<b>Protection/Environmental</b>	
Protection	Accurate over current, voltage load protection
	"V0" fire protection
Working temperature	<b>-30°C~+70°C</b> (-22°F~+158°F)
Working humidity	<90% RH
<b>Physical Properties</b>	
Weight	160g(0.35lb)
Dimension(LxWxH)	88mmx37mmx138mm (3.46"x1.46"x5.43")
Installation	Wall mount
Color	Grey
Input	Palisade terminal
Output	DC output wire 60mm (interface: $\phi 5.5 \times \phi 2.1$ )
<b>Safety Standards</b>	
Certification	CE

Dimensions (mm/inch)

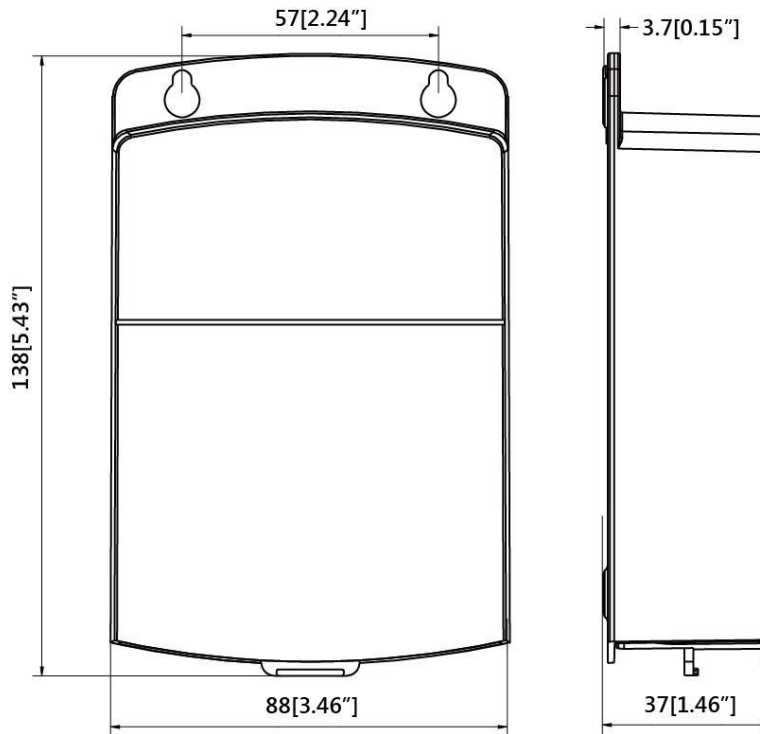

Application

