

DH-PFB302S

Wall Mount Bracket with IP66 Junction Box

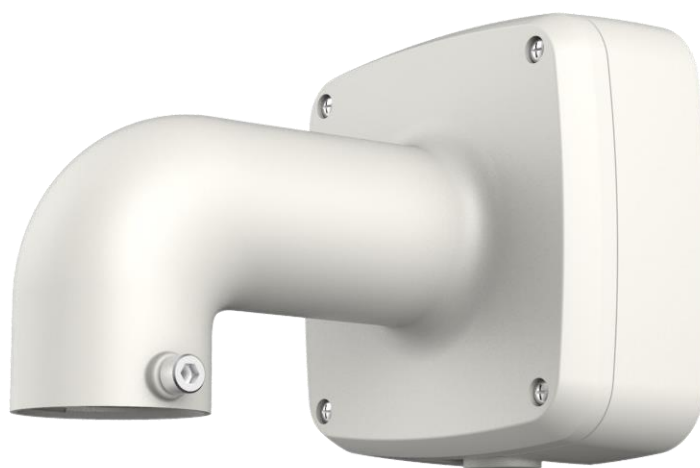

Features

- Neat & Integrated design
- Material: Aluminum
- Wall mount bracket with IP66 junction box

Technical Specifications

Model	DH-PFB302S
General	
Material	Aluminum

Camera Mount Series | DH-PFB302S

Dimension (W x H x D)	134.0mmx133.5mmx187.5mm (5.28"x5.25"x7.38")
Pipe thread	G3/4"
Weight	0.7kg(1.54lb)
Load bearing	4.0kg(8.82lb)
Color	White
Protection	IP66
Operating temperature	-40°C ~60°C(-40°F ~140°F)
Humidity	0~90% RH
Applicable model	Please see "Accessory Selection"

Order Information

Type	Part Number	Description
Camera mount	DH-PFB302S	Wall mount bracket with IP66 junction box
	PFB302S	Wall mount bracket with IP66 junction box

Dimensions (mm/inch)

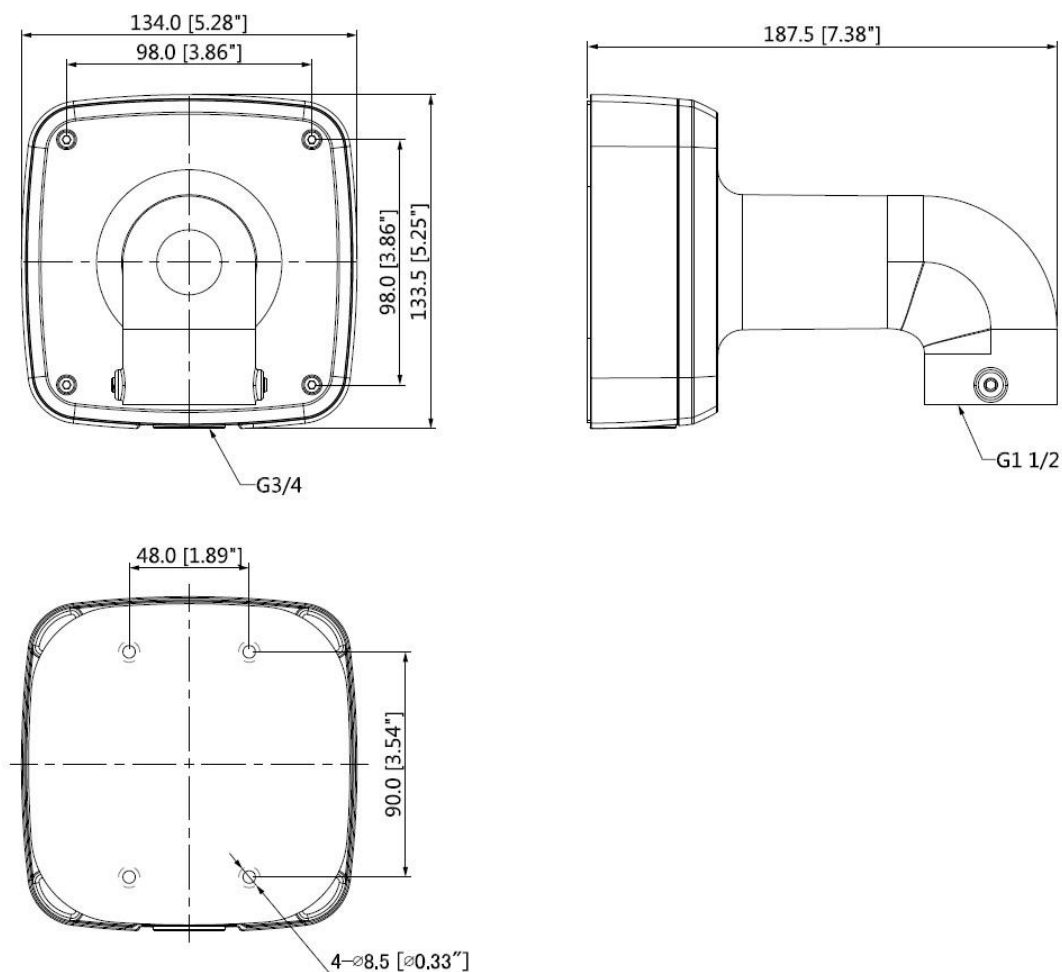

Application

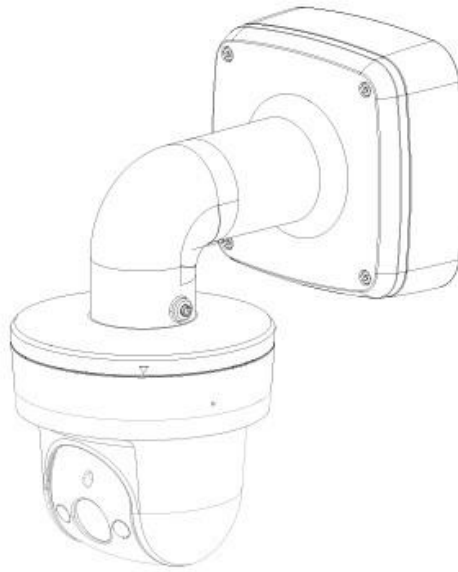

Package Information

- Wall mount bracket with IP66 junction box *1
- ST4.2x25 screw *4
- Plastic Anchor: 4
- S3.0 wrench *1