

## DH-PFB201C

### In-ceiling Mount Bracket



### Features

- Material: SECC & PC
- In-ceiling Mount Bracket
- Neat & Integrated design

### Specifications

<b>Model</b>	<b>DH-PFB201C</b>
<b>General</b>	
Material	SECC & PC
Dimension	Φ211.0x88.0mm
Inch Thread	G3/4"
Operating Temperature	-40°C ~60°C
Humidity	0~90% RH
Load Bearing	1.5Kg
Weight	0.61Kg
Color	White
Applicable Model	Please see "Accessory Selection"

# DH-PFB201C

## Dimensions (mm)

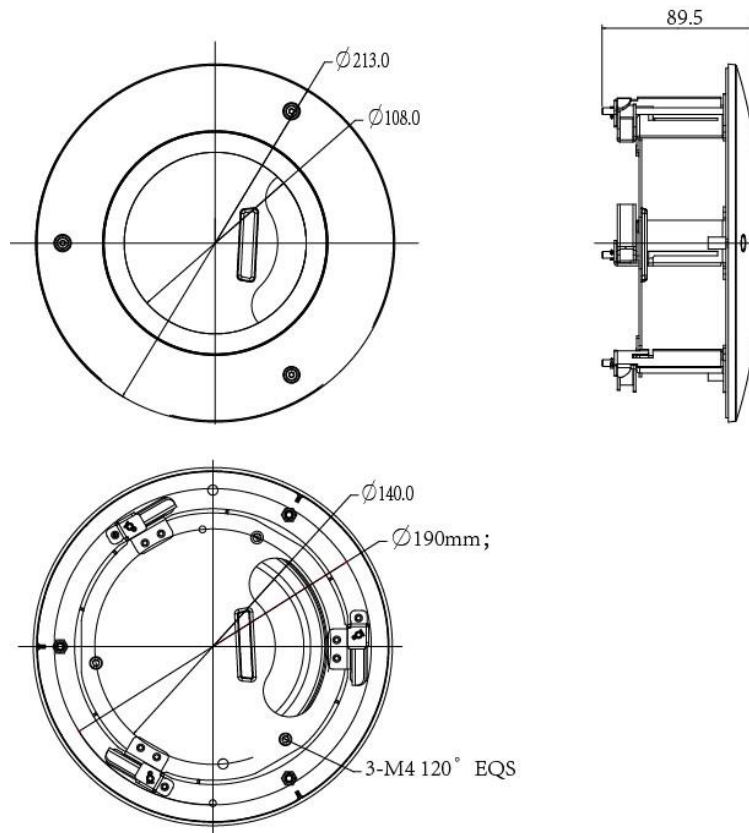

## Application

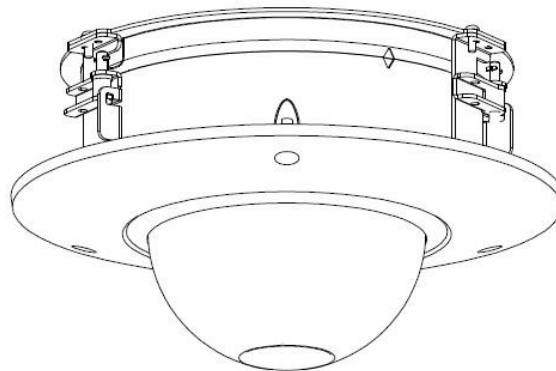

**Dahua Technology Co., Ltd.**

1199 BinAn Road, Binjiang District, Hangzhou, China

Tel: +86-571-87688883

Fax: +86-571-87688815 Email:

overseas@dahuatech.com

www.dahuasecurity.com

\*Design and specifications are subject to change without notice.

© 2016 Dahua Technology Co., Ltd.